

**M**  
**M**  
**MAZZER**



**Super Jolly**

*Your coffee wingman*



# Super Jolly

Designed for **small/medium** sized cafés looking for **quality, ease of use** and **consistency**. Its updated, iconic design makes the Super Jolly a **modern classic**, honoring the 1971 Jolly model.

## → WHAT'S NEW

### Twice as fast

Compared to the previous model (range: 4,0–5,2 g/s) thanks to its new bespoke high torque asynchronous motor.

### Maximum Consistency

The new motor delivers enhanced performance while staying cool. Grind size stays consistent across all workloads, eliminating the need for adjustments.

OPTIONAL

### Magnetic Dosing Cup

Super Jolly works with both the portafilter and the optional Dosing Cup (ø58 mm, 30 g capacity).



## → NEW BURRS

 **64 mm**  
flat burrs

CHOOSE WHICH BURRS TO INSTALL ON YOUR GRINDER



STANDARD  
**205D**

**FLAVOR PROFILE:** Classic, well-balanced cups with relevant body and chocolatey notes.

**IDEAL FOR:** medium to dark roasts and milk-based drinks.

**MATERIAL:** Bearing steel.



ZZ BURRS  
**ZZ k206P**

**FLAVOR PROFILE:** Well-rounded cups with a complex structure of flavours, nice acidity, fruity notes, a soft, velvety texture, and light-medium body.

**IDEAL FOR:** light and medium roasts.

**MATERIAL:** Special steel ensures longer lifespan and ultra-precise machining for maximum consistency.

**INNOVATIVE GEOMETRY:** long-winded, continuous, sharp teeth which gradually refine the particle to the end.

## → FEATURE HIGHLIGHTS



**CALIBRATION RING**  
A numbered ring to set a zero point where the burrs touch, and always know your exact grind setting



**EASY TO CLEAN**  
Easily access and clean the grinding chamber without losing your grind settings



**GRIND FLOW CONTROL SYSTEM**  
Achieve a uniform grind, reduce clumping and keep the counter free from coffee dust

## FEATURES



Easy to clean: access the grinding chamber without losing your grind settings



Multi-adjustable portafilter holder. Hands-free grinding with the portafilter/Dosing Cup activated grind button



GFC damper to customize grind flow, reduce clumping and keep the counter free from coffee dust (Hybrid and Antidust)



Calibration Ring: a numbered ring that lets you set a zero point where the burrs touch, so you always know your exact grind setting



Grinding statistics, IoT connectivity for remote data monitoring, Firmware upgrades, service needs alerts



Protect your coffee beans from temperature exposure with the double fan cooling system

## TECH SPECS

**POWER** • 550 Watt

**GRIND ADJUSTMENT** • stepless micrometrical

**GRIND SPEED** • 1400 rpm (50 Hz) - 1600 rpm (60Hz)

**BURRS** • Ø 64 mm flat (2½ in) | 205D or ZZ k206P

**BODY** • aluminum die casting

**HOPPER CAPACITY** • 1.1 kg (2.4 lbs) or 280gr (0.62 lbs)

**NET WEIGH** • 16.5 kg (36.3 lbs)

**EQUIPMENT FEATURES** • IoT, Tag holder, GFC Kit

**OPTIONAL** • aluminum hand tamper, Dosing Cup

## COLORS



\*On request with extra charge

## CERTIFICATIONS



## LEARN MORE



ESPRESSO

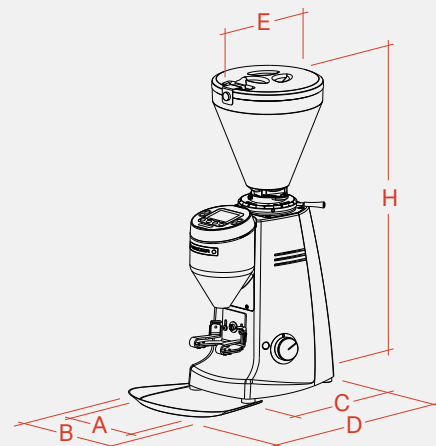

A	207 mm - 8¼ in	D	404 mm - 16 in
B	240 mm - 9½ in	H	601 mm - 23½ in
C	255 mm - 10 in	E	209 mm - 8¼ in



MAZZER LUIGI S.p.a.  
Via Moglianese Gardigiano 113  
30037 Scorzè (VE) - Italy  
mazzer@mazzer.com  
www.mazzer.com

DPSJ00032026

The manufacturer reserves the right to change specifications without notice